



***WATER
TRANSFER
PUMP***

***TRASH
PUMP***

***NYLON
CHEMICAL
PUMP***

OPERATION MANUAL





Introduction

- 4 Using the Operators Manual

Product Identification

- 5 Water Pump
- 5 Engine

Safety

- 6 Safety Rules
- 6 Hazard Symbols and Meanings

Water Pump Components

- 11 Component Chart

Assembly

- 12 Connect Suction Hose to Pump
- 12 Attach Suction Hose to Strainer Basket
- 12 Connect Discharge Hose

Operation

- 14 What is "Head"
- 14 Move Water Pump to Safe Location
- 15 Prime the Water Pump
- 16 Locate Strainer Basket Into Water Source

Starting The Water Pump

- 17 Starting the Water Pump

Stopping The Water Pump

- 19 Stopping the Water Pump
- 19 Drain and Flush Water Pump



INTRODUCTION



Attention: Read through the complete manual prior to the initial use of your water pump

Using the Operator's manual

The operating manual is an important part of your water pump and should be read thoroughly before initial use, and referred to often to make sure adequate safety and service concerns are being addressed.

Reading the owner's manual thoroughly will help avoid any personal injury or damage to your machine. By knowing how best to operate this machine you will be better positioned to show others who may also operate the unit.

This manual contains information for the complete range of BE water pumps, and is placed in order starting from the safety requirements to the operating functions of your machine. You can refer back to the manual at any time to help troubleshoot any specific operating functions, so store it with the machine at all times.



Record Identification Numbers

Water Pump

If you need to contact an Authorized Dealer or Customer Service line (1-866-850-6662) for information on servicing, always provide the product model and identification numbers.

You will need to locate the model and serial number for the machine and record the information in the places provided below.

Date of Purchase:

Dealer Name:

Dealer Phone:

Product Identification Numbers

Model Number:

Serial Number:

Engine

Horse Power:

Save these Instructions

Safety Rules



This is the safety alert symbol. It is used to alert you to potential personal injury hazards. Obey all safety messages that follow this symbol to avoid possible injury or death.

The safety alert symbol () is used with a signal word (DANGER, CAUTION, WARNING), a pictorial and/or a safety message to alert you to hazards.

DANGER indicates a hazard which, if not avoided, will result in death or serious injury.

WARNING indicates a hazard which, if not avoided, could result in death or serious injury.

CAUTION indicates a hazard which, if not avoided, might result in minor or moderate injury.

NOTICE indicates a situation that could result in equipment damage. Follow safety messages to avoid or reduce the risk of injury or death.

Hazard Symbols and Meanings



EXPLOSION



FIRE



ELECTRIC SHOCK



KICKBACK



HOT SURFACE



TOXIC FUMES



MOVING PARTS



SLIPPERY



READ MANUAL

⚠ WARNING



Running engine gives off carbon monoxide, an odorless, colorless, poisonous gas.

Breathing carbon monoxide can cause headache, fatigue, dizziness, vomiting, confusion, seizures, nausea, fainting or death.

- Operate water pump ONLY outdoors.
- Keep exhaust gas from entering a confined area through windows, doors, ventilation intakes, or other openings.
- DO NOT start or run engine indoors or in an enclosed area, even if windows and doors are open.

⚠ WARNING



Use of water pump can create puddles and slippery surfaces.

- Operate water pump from a stable surface.
- The area should have adequate slopes and drainage to reduce the possibility of a fall due to slippery surfaces.

⚠ WARNING



Unintentional sparking can result in fire or electric shock.

When Adjusting or Making Repairs to Your Water Pump

- Disconnect the spark plug wire from the spark plug and place the wire where it cannot contact spark plug.

When Testing for Engine Spark

- Use approved spark plug tester.
- DO NOT check for spark with spark plug removed.

⚠ WARNING



Fuel and its vapors are extremely flammable and explosive.



Fire or explosion can cause severe burns or death.

When Adding or Draining Fuel

- Turn water pump OFF and let it cool at least 2 minutes before removing fuel cap. Loosen cap slowly to relieve pressure in tank.
- Fill or drain fuel tank outdoors.
- DO NOT overfill tank. Allow space for fuel expansion.
- If fuel spills, wait until it evaporates before starting engine.
- Keep fuel away from sparks, open flames, pilot lights, heat, and other ignition sources.
- DO NOT light a cigarette or smoke.

When Starting Equipment

- Ensure spark plug, muffler, fuel cap, and air cleaner are in place.
- DO NOT crank engine with spark plug removed.

When Operating Equipment

- DO NOT pump flammable liquids, such as fuel or fuel oils.
- This water pump is not for use in mobile equipment or marine applications.
- DO NOT tip engine or equipment at angle which causes fuel to spill.
- Secure water pump. Loads from hoses may cause tipover.



When Transporting or Repairing Equipment

- Transport/repair with fuel tank EMPTY or with fuel shutoff valve OFF.
- Disconnect spark plug wire.

When Storing Fuel or Equipment with Fuel in Tank

- Store away from furnaces, stoves, water heaters, clothes dryers, or other appliances that have pilot light or other ignition source because they can ignite fuel vapors.

⚠ WARNING	
	<p>Starter cord kickback (rapid retraction) can result in bodily injury. Kickback will pull hand and arm toward engine faster than you can let go.</p> <p>Broken bones, fractures, bruises, or sprains could result.</p> <p>Keep hands and body clear from discharge of pump.</p>
<ul style="list-style-type: none"> ▪ When starting engine, pull cord slowly until resistance is felt and then pull rapidly to avoid kickback. ▪ Secure discharge hose to avoid whipping. 	

⚠ WARNING	
 	<p>Contact with muffler area can result in serious burns.</p> <p>Exhaust heat/gases can ignite combustibles, structures or damage fuel tank causing a fire.</p>
<ul style="list-style-type: none"> ▪ DO NOT touch hot parts and AVOID hot exhaust gases. ▪ Allow equipment to cool before touching. ▪ Keep at least 5 feet (1.5 m) of clearance on all sides of pressure washer including overhead. 	

⚠ WARNING	
	<p>Starter and other rotating parts can entangle hands, hair, clothing, or accessories.</p>
<ul style="list-style-type: none"> ▪ NEVER place hands or body parts inside of running pump or hoses. ▪ Never operate water pump without protective housing or covers. ▪ DO NOT wear loose clothing or anything that may be caught in the starter or other rotating parts. ▪ Tie up long hair and remove jewelry. 	



SAFETY

CAUTION

Excessively high operating speeds increase risk of injury and damage to water pump.

Excessively low speeds impose a heavy load.

- DO NOT tamper with the governed speed.
- DO NOT modify the water pump.
- DO NOT allow unqualified persons or children to operate or service water pump.

NOTICE

Improper treatment of water pump can damage it and shorten its life.

- If you have questions about intended use, ask dealer or contact nearest authorized dealer.
- Be sure pump chamber is filled with water before starting the engine. Never run pump without priming.
- Use a non-collapseable hose on the suction side of the hose.
- Use water pump only for intended uses.
- Pumping sea water, beverages, acids, chemical solutions, or any other liquid that promotes corrosion can damage the pump.
- Ensure all connections are air tight.
- DO NOT obstruct the suction or discharge hose in any way.
- NEVER operate pump without strainer basket connected to end of suction hose.
- NEVER allow vehicles to drive over hoses. If a hose must be positioned across a roadway, use planking on each side of hose to allow vehicles to pass over without obstructing or collapsing hose.
- Anchor pump to avoid equipment movement.
- Keep equipment away from edge of river or lake where it could cause the bank to collapse.
- DO NOT insert any objects through cooling slots.
- NEVER operate units with broken or missing parts, or without protective housing or covers.
- DO NOT by-pass any safety device on this machine.
- NEVER move machine by pulling on hoses. Use frame on unit.
- Check fuel system for leaks or signs of deterioration, such as chafed or spongy hose, loose or missing clamps, or damaged tank or cap. Correct all defects before operating water pump.

WATER PUMP COMPONENTS



Read this operator's manual and safety rules before operating your water pump.

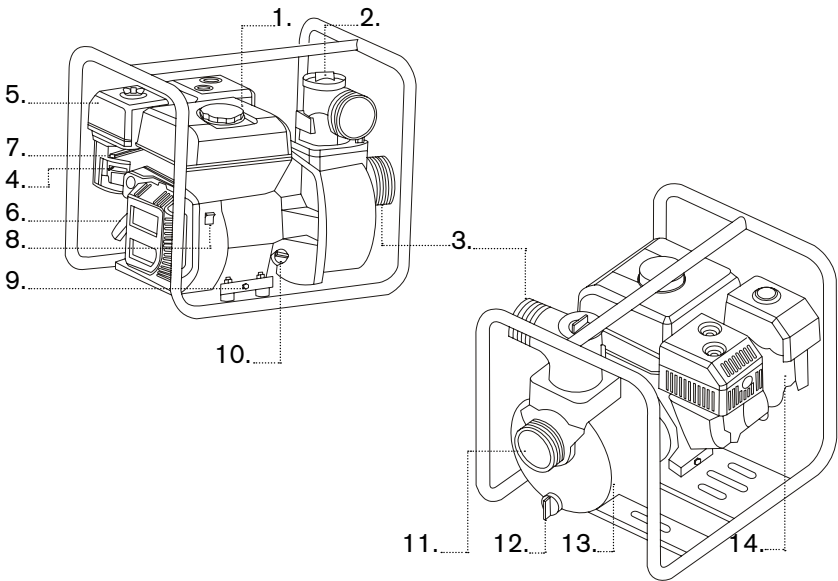

1. **Fuel Tank** Fill tank with regular unleaded fuel. Always leave room for fuel expansion.
2. **Priming Plug** Fill pump with water here to prime pump before starting.
3. **Discharge Outlet** Connect discharge hose here.
4. **Choke Lever** Prepares a cold engine for starting.
5. **Air Cleaner** Protects engine by filtering dust and debris out of intake air.
6. **Recoil Starter** Used for starting the engine manually.
7. **Engine Speed Lever** Used to adjust engine speed to control pump output.
8. **On/Off Switch** Set this switch to "On" before using recoil starter. Set switch to "Off" to stop a running engine.
9. **Oil Drain** Drain engine oil here.
10. **Oil Fill** Check and add engine oil here.
11. **Suction Inlet** Connect reinforced suction hose here.
12. **Water Drain Plug** Remove to drain water from pump and flush internal components with clean water.
13. **Pump Chamber** Be sure to fill with water before starting.
14. **Fuel Shutoff Valve** Used to turn fuel supply on and off to engine.

Item Not Shown:

Strainer Basket Used to limit passage of abrasive materials into the pump.

Your water pump requires some set up and is ready for use after it has been properly serviced with the recommended oil and fuel.

If you have any problems with the set up of your water pump, please call the pressure washer help line at **1-866-850-6662** If calling for assistance, please have the model and serial number from the data tag available.

Connect Suction Hose to Pump

1. Slide hose clamp (A) over end of hose (B). Slide suction hose onto hose barb (C). Tighten hose clamp securely to the hose.

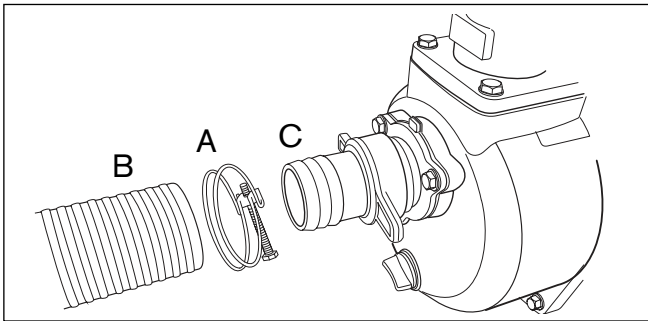

Attach Suction Hose to Strainer basket

1. Slide hose clamp over hose. Attach open end of suction hose to strainer hose barb. Tighten hose clamp securely.

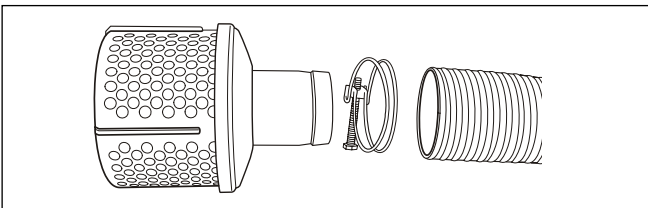

Connect Discharge Hose (Optional)

If desired, use a commercially available hose. **DO NOT** use a hose with an inside diameter smaller than the pump's discharge port size.

1. Slide barb cuff over hose barb. Insert rubber seal into end of barb cuff as shown earlier.
2. Screw hose barb assembly onto pump in clockwise rotation until hose barb assembly is tightened securely.

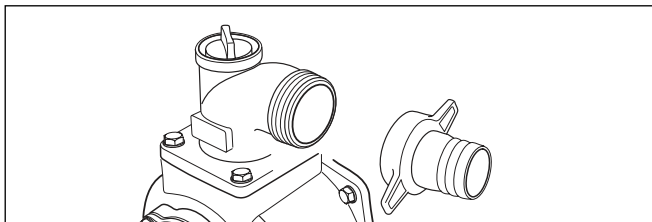

3. Slide hose clamp over end of discharge hose. Slide discharge hose onto hose barb. Tighten hose clamp securely.

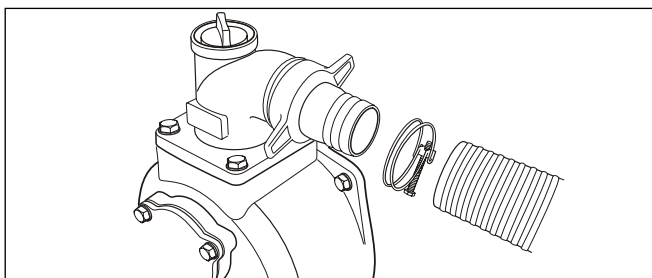

4. You may choose to assemble the discharge and suction hose as shown above or by using camlock connections. Camlocks are another commonly used water pump connection.



OPERATION

What is “Head”

Head refers to the height of a column of water that can be delivered by the discharge of the pump.

Suction Head is the vertical distance between the center of the pump and the surface of the liquid on the suction side of the pump. May also be referred to as “suction lift”. The atmospheric pressure of 14.7 psi at sea level limits suction head lift to less than approximately 26 feet for any pump.

Discharge Head is the vertical distance between the pump’s discharge port and the point of discharge, which is the liquid surface if the hose is submerged or pumping into the bottom of a tank.

Total Head is the sum of the suction head value plus the discharge head value.

As water pumping height increases, pump output decreases. The length, type, and size of the suction and discharge hoses can also significantly affect pump output.

It is important for the suction operation to be the shorter part of the total pumping action. This will decrease the priming time and improve pump performance by increasing the discharge head.

Suction head is a maximum of 25 feet and discharge head should be a maximum of 81 feet. Total head can not be more than 106 feet as shown on next page.

Move Water Pump to Safe Operating Location

For best pump performance, locate the pump on a flat, level surface as close as possible to the water to be pumped. Secure water pump to avoid tipover. Use hoses that are no longer than necessary.

IMPORTANT: Direct open end of discharge hose away from home, electrical devices or anything not desired to get wet.

WARNING



Fuel and its vapors are extremely flammable and explosive.



Fire or explosion can cause severe burns or death.

- This water pump is not for use in mobile equipment or marine applications
- DO NOT tip engine or equipment at angle which causes fuel to spill.
- Secure water pump. Loads from hoses may cause tip over.

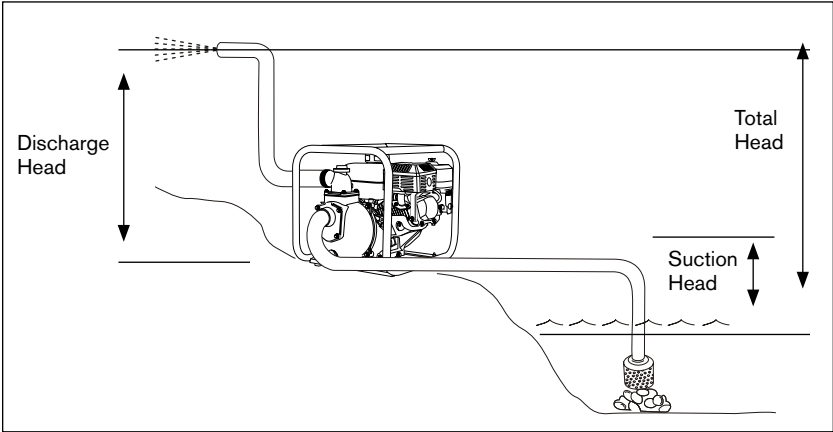

Prime the Water Pump

1. Remove priming plug from top of pump.
2. Fill pump with clean, clear water up to top of discharge outlet.
3. Replace priming plug.

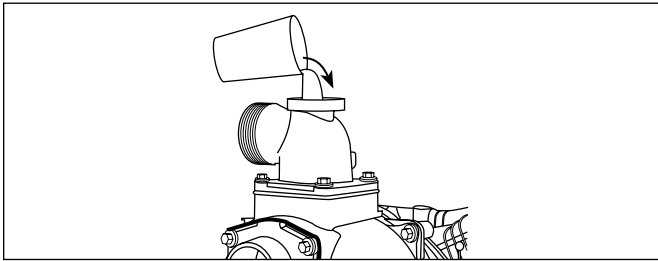

NOTICE

Improper treatment of water pump can damage it and shorten its life.

- Be sure chamber is filled with water before starting the engine.
- NEVER run pump without priming

Locate Strainer Basket Into Water Source

Place strainer basket into water to be pumped. Basket must be fully immersed.

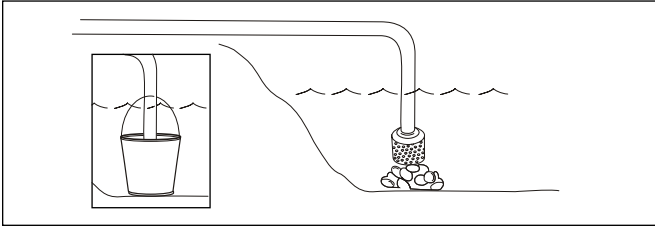
**NOTICE**

Improper treatment of water pump can damage it and shorten its life.

- NEVER operate pump without strainer connected to end of suction hose.
- Keep strainer out of sand or silt, place in bucket or on stones.
- DO NOT let pump run dry or damage to seals may result.

Starting the Water Pump

Use the following start instructions:

1. Make sure unit is on a flat, level surface and pump chamber is primed.
2. Turn fuel valve (1) to "On" position. The fuel valve handle will be vertical (pointing toward the ground).

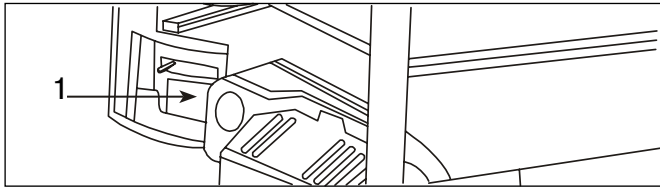

3. Push on/off switch (2) to "On" position.
4. Move engine speed lever (3) to "Fast" () position.

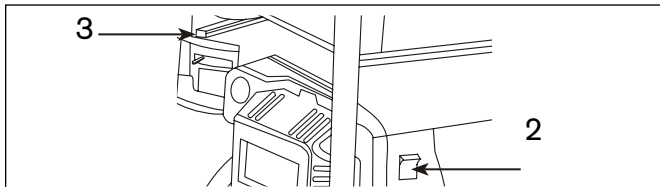

5. Move choke lever (4) to "On" position.

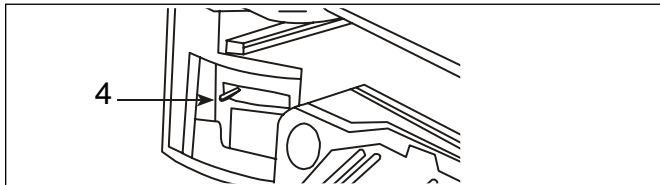

6. Grasp recoil handle and pull slowly until slight resistance is felt. Then pull handle rapidly to overcome compression, prevent kickback and start engine.

WARNING



Starter cord kickback (rapid retraction) can result in bodily injury. Kickback will pull hand and arm toward engine faster than you can let go.

Broken bones, fractures, bruises, or sprains could result.

- When starting engine, pull cord slowly until resistance is felt and then pull rapidly to avoid kickback.



STARTING THE WATER PUMP

IMPORTANT: If excessive fuel is present in the air/fuel mixture causing a “flooded” condition, move choke lever to “Run” position and pull handle repeatedly until engine starts.

7. Move choke lever to “Run” position a short distance at a time over several seconds in warm weather or minutes in cold weather. Let engine run smoothly before each change. Operate with choke in “Run” position.

IMPORTANT: It may take a few minutes for water pump to begin pumping water.

WARNING



Contact with muffler area can result in serious burns.



Exhaust heat/gases can ignite combustibles, structures or damage fuel tank causing a fire.

- DO NOT touch hot parts and AVOID hot exhaust gases.
- Allow equipment to cool before touching.
- Keep at least 5 feet (1.5 m) of clearance on all sides of pressure washer including overhead.

Pump output is controlled by adjusting engine speed. Moving the engine speed lever in the “Fast” direction will increase pump output, and moving the engine speed lever in the “Slow” direction will decrease pump output.

Stopping the Water Pump

1. Move engine speed lever to "Slow" position.
2. Push on/off switch to "Off" position.
3. Turn fuel valve to "Off" position.

WARNING



Backfire, fire or engine damage could occur.

- DO NOT stop engine by moving choke control to "Choke" position.

Drain and Flush Water Pump

1. Disconnect and drain suction and discharge hoses.
2. Remove drain plug at bottom of pump.

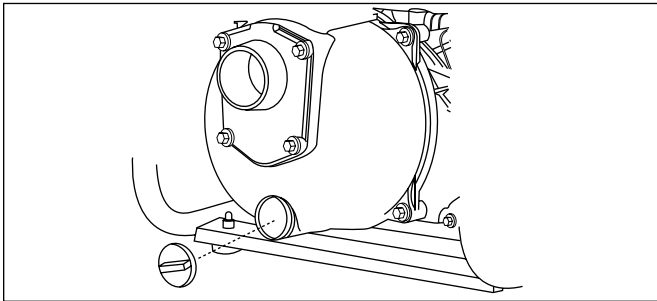

3. Remove primer plug from top of pump and flush internal components of pump with clean water.

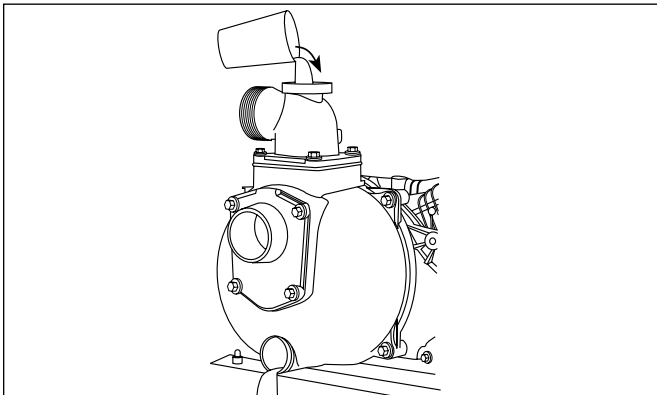

4. Replace both plugs and finger tighten.



**If you need assistance with the
assembly or operation of
this Water Pump please call**

1-866-850-6662